

EEO 401
Digital Signal Processing
Prof. Mark Fowler

Note Set #12

- DT Filters
- Reading Assignment: Sect. 5.4 of Proakis & Manolakis

Ideal LP Filter

Put in the signal we want “passed”.

Suppose that
 $X^f(\omega) = 0 \quad |\omega| \notin [\omega_o, \pi]$

$x[n]$

$H^f(\omega)$

$y[n] = Cx[n - n_o]$

Want to get out the signal we want “passed”... but we can accept a “small” delay ($n_o > 0$) and an amplitude scaling factor ($C > 0$)

From the time-shift property of the DTFT then we need:

$$Y^f(\omega) = X^f(\omega) C e^{-j\omega n_o}$$

Taking $C = 1$ is typical

Thus we should treat this as $H^f(\omega)$, so we have:

$$|H^f(\omega)| = |C e^{-j\omega n_o}| = C$$

$$\angle H^f(\omega) = \angle C e^{-j\omega n_o} = -\omega n_o$$

For ω in the “pass band” of the filter
 $\omega \in [-\omega_o, \omega_o]$

Line of slope $-n_o$
“Linear Phase”

So... for an ideal low-pass filter (LPF) we have:

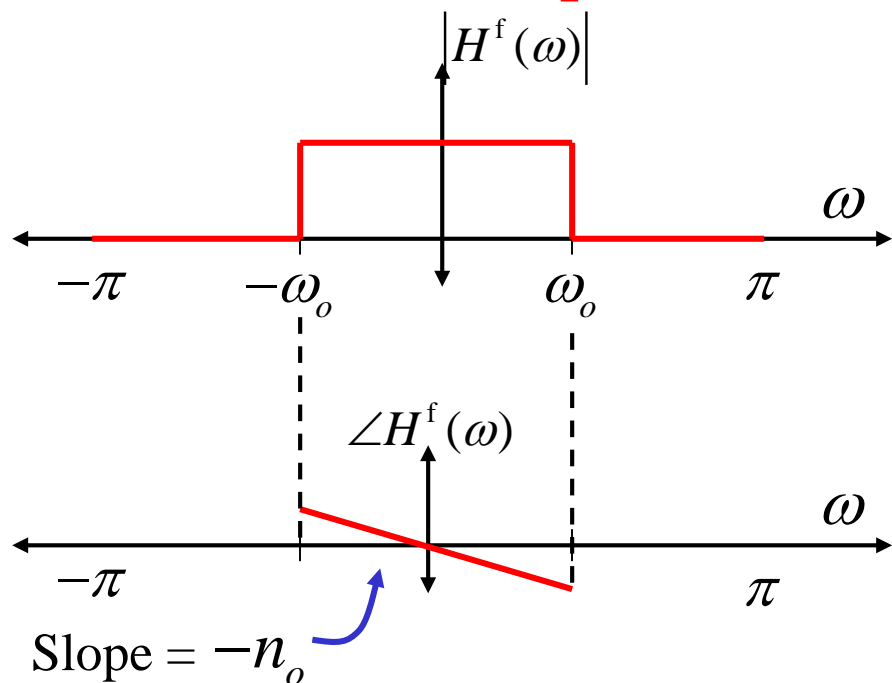

$$H(\omega) = \begin{cases} Ce^{-j\omega t_d}, & -\omega_o < \omega < \omega_o \\ 0, & \text{otherwise} \end{cases}$$

Phase is undefined in stop band:

$$0 = 0e^{j\theta}$$

$$\angle 0 = ?$$

Summary of Ideal Filters

1. Magnitude Response:
 - a. Constant in Passband
 - b. Zero in Stopband
2. Phase Response
 - a. Linear in Passband (negative slope = delay)
 - b. Undefined in Stopband

i.e. phase is undefined for frequencies outside the ideal passband

Remember that for DT the frequency response is a DTFT so is periodic:

Ideal Lowpass Filter (LPF)

Cut-off frequency = ω_o rad/sample

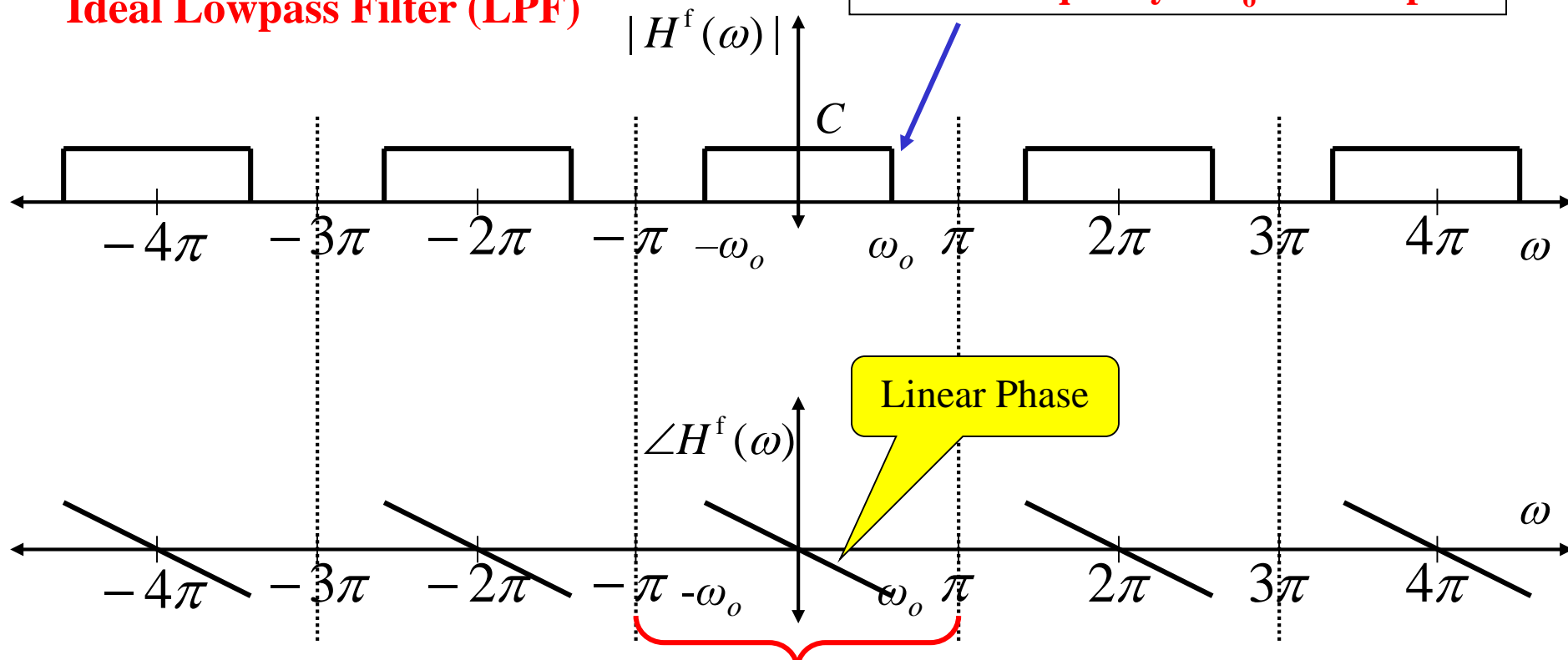

As always with DT... only need to look here

Why can't an ideal filter exist in practice??

To answer this we will find the filter's impulse response, which is the IDTFT of the frequency response. The frequency response of the ideal LPF is

$$H(\omega) = \begin{cases} Ce^{-j\omega t_d}, & -\omega_o < \omega < \omega_o \\ 0, & \text{otherwise} \end{cases}$$

Using the IDTFT of a rectangle together with the time-shift property gives

So the impulse response is: $h[n] = (\omega_o / \pi) \text{sinc}[(\omega_o / \pi)(n - n_o)]$

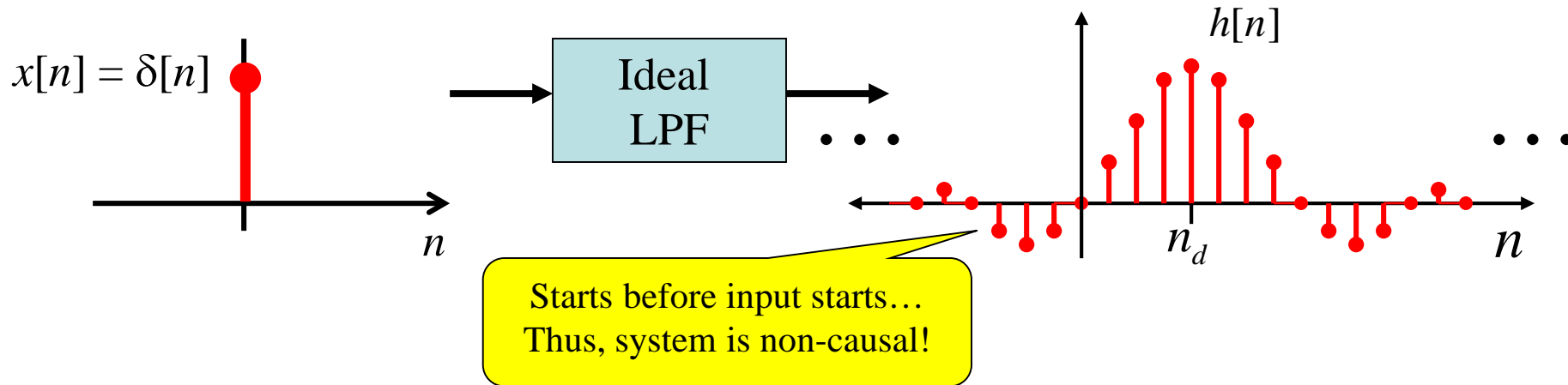

Ideal Filter Types

So far we've limited discussion to ideal lowpass filters. These ideas can be extended to other filter types. To be ideal they need to have

- constant magnitude
- linear phase

in their passband(s).

Note: Although it is not shown here, all of these repeat periodically outside $[-\pi, \pi]$.

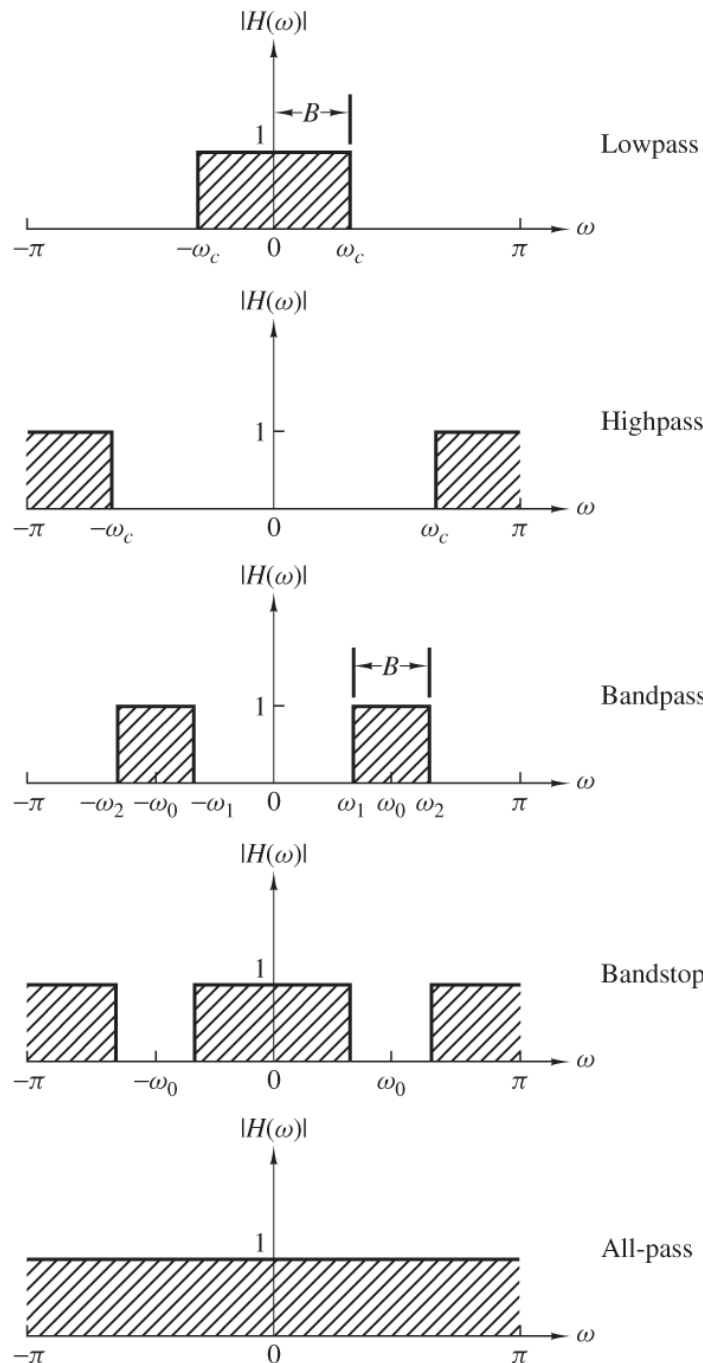

Pole-Zero Placement to Yield Filter Types

Although there are high-powered methods of filter design... it is useful to understand how to achieve some simple filters via proper placement of poles and zeros.

$$H^z(z) = \frac{\sum_{k=0}^M b_k z^{-k}}{1 + \sum_{k=1}^N a_k z^{-k}} = \frac{b_o \prod_{k=1}^M (1 - z_k z^{-1})}{\prod_{k=1}^N (1 - p_k z^{-1})}$$

b_o sets overall gain of filter

The locations of the poles p_k and zeros z_k impact the shape of the frequency response

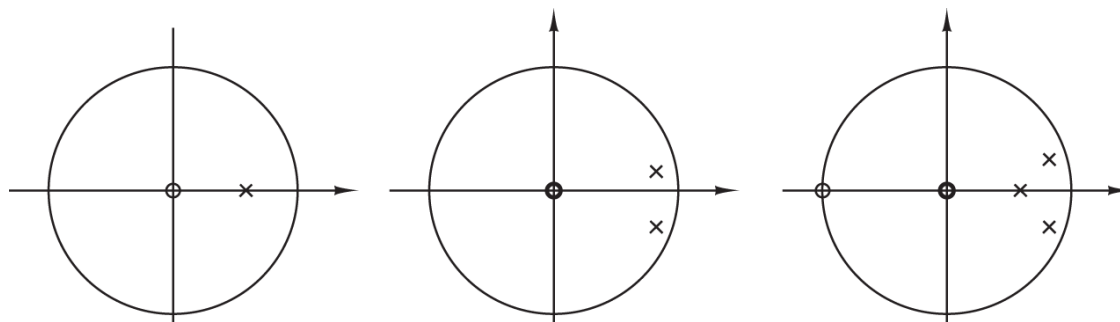

Lowpass: poles near $z = 1 = e^{j0}$

$\omega = 0$

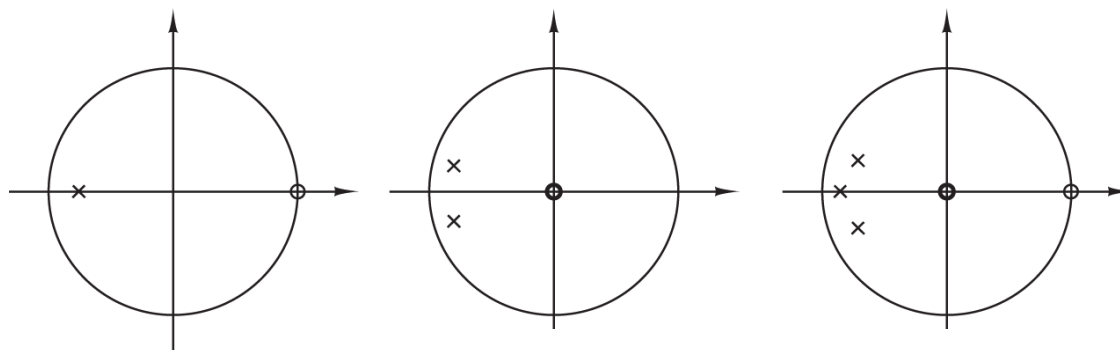

Highpass: poles near $z = -1 = e^{\pm j\pi}$

$\omega = \pm\pi$

Effect of Poles & Zeros on Frequency Response of DT filters

Note: Including a pole or zero at the origin ...

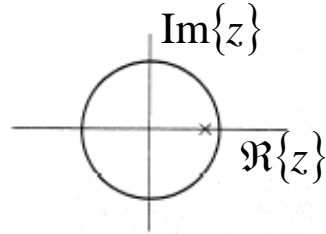

(a)

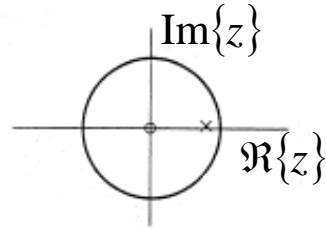
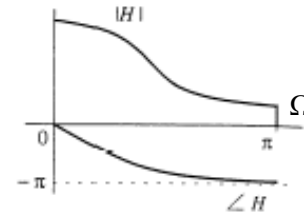

(b)

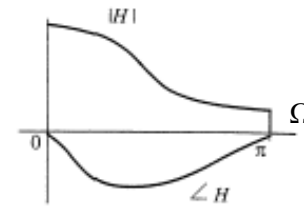

...doesn't change the magnitude but does change the phase

Placing a zero at $\pm\pi$...

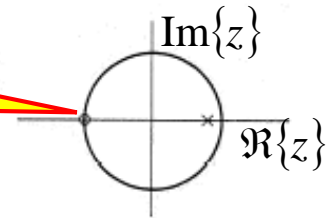

(c)

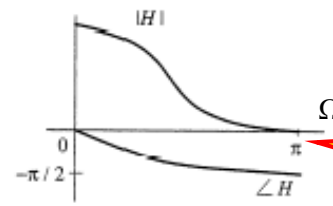

...makes $|H(\pi)| = 0$

Placing more zeros/poles...

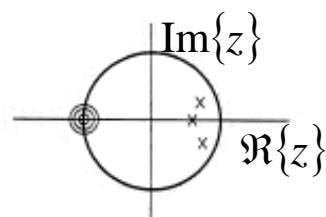

(d)

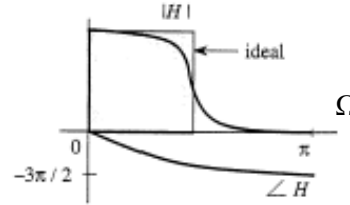

... gives sharper transitions.

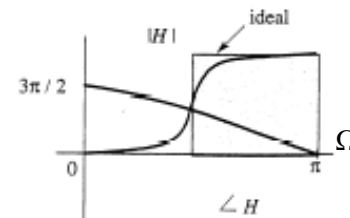
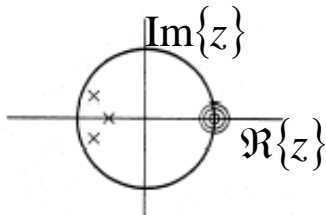
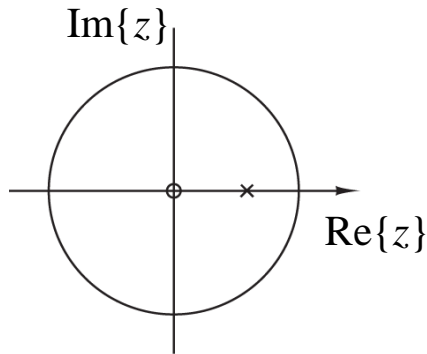

Figure from B.P. Lathi, Signal Processing and Linear Systems

Simple Lowpass Filters

Case #1: $H_1^z(z) = \frac{1-a}{1-az^{-1}}$



Case #2: $H_2^z(z) = \frac{1-a}{2} \left[\frac{1+z^{-1}}{1-az^{-1}} \right]$

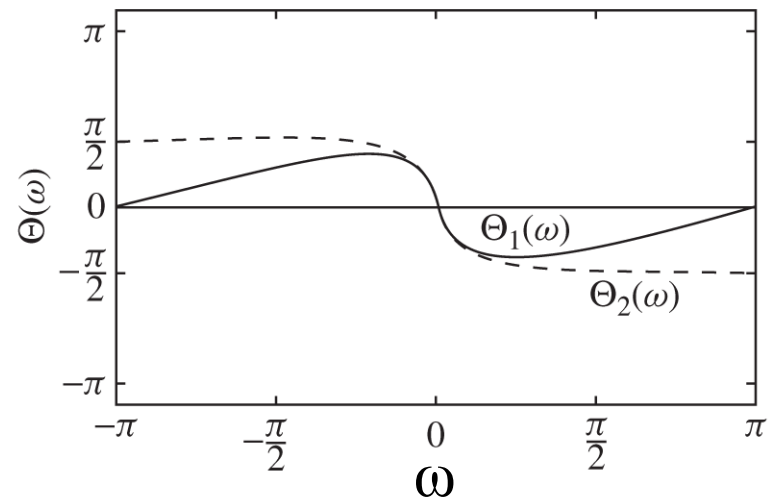
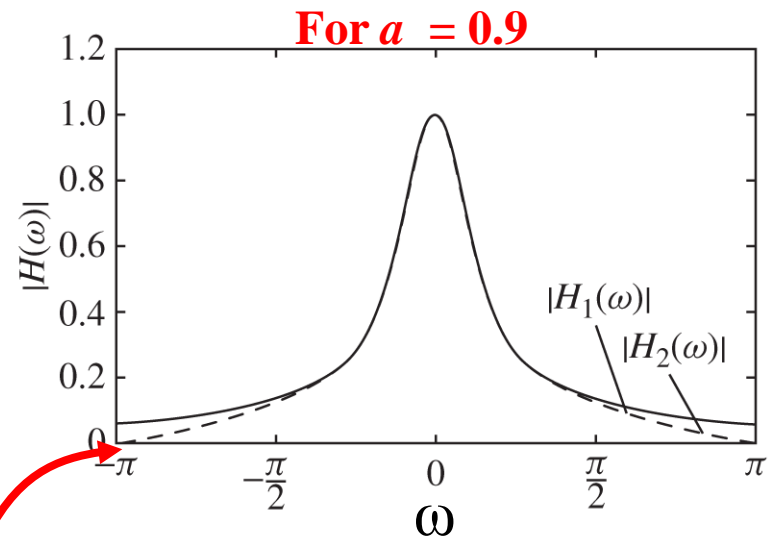
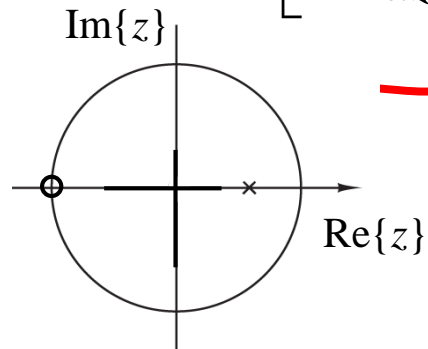

MATLAB for Case #1 w/ $a = 0.9$

```
>> w=linspace(-pi,pi,2000);
>> b = 0.1;
>> b = [1 -0.9];
>> H=freqz(b,a,w);
```

Simple Highpass Filters

Looking back at pole-zero plots for HPF and LPF we see that each LPF can be converted into a HPF by flipping: $z \rightarrow -z$

$$\text{LPF: } H_2^z(z) = \frac{1-a}{2} \left[\frac{1+z^{-1}}{1-az^{-1}} \right] \xrightarrow{\text{red arrow}} \text{HPF: } H_3^z(z) = H_2^z(-z) = \frac{1-a}{2} \left[\frac{1-z^{-1}}{1+az^{-1}} \right]$$

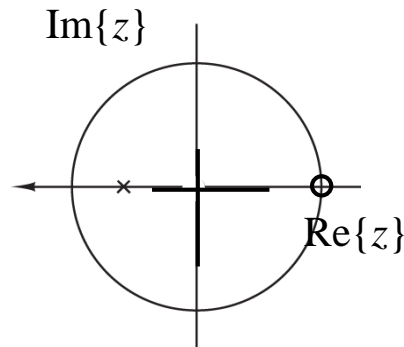
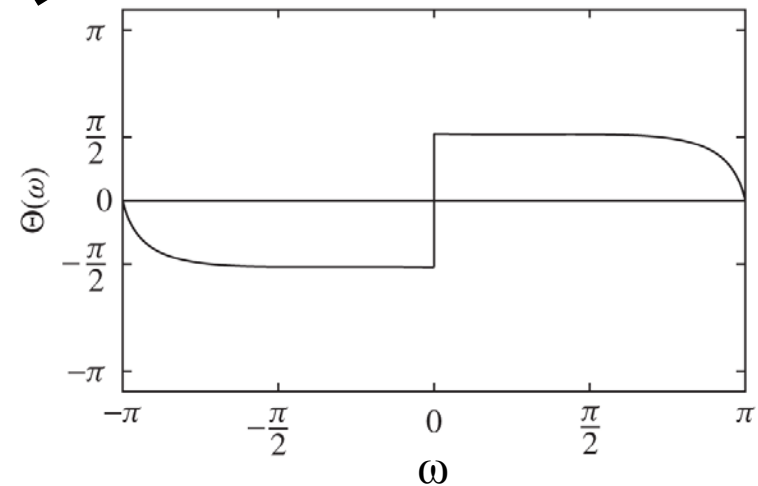
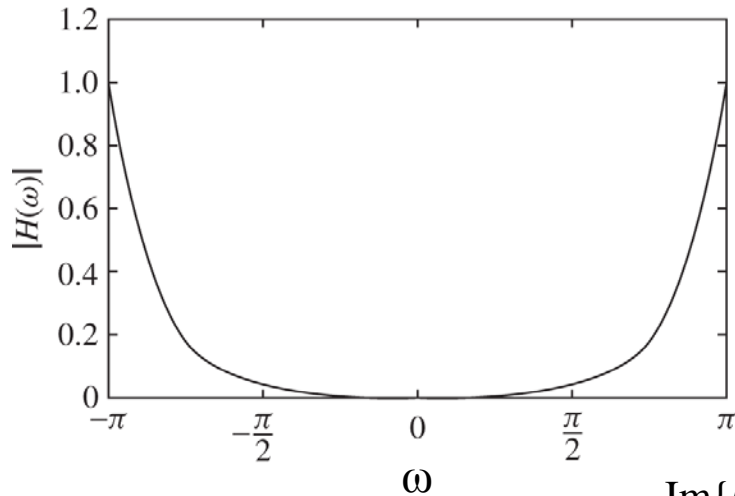

Simple Bandpass Filters

We can get a simple BPF if we put poles at $p_{1,2} = re^{\pm j\pi/2}$

... and zeros at $z = \pm 1$

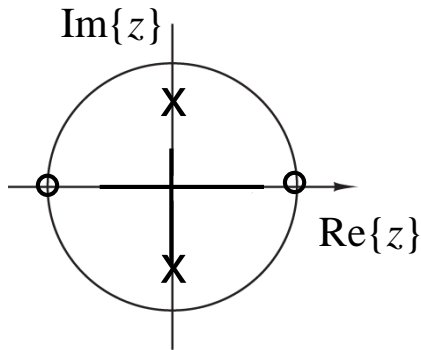

$$H^z(z) = G \left[\frac{(z-1)(z+1)}{(z-jr)(z+jr)} \right]$$
$$= G \left[\frac{z^2 - 1}{z^2 + r^2} \right]$$

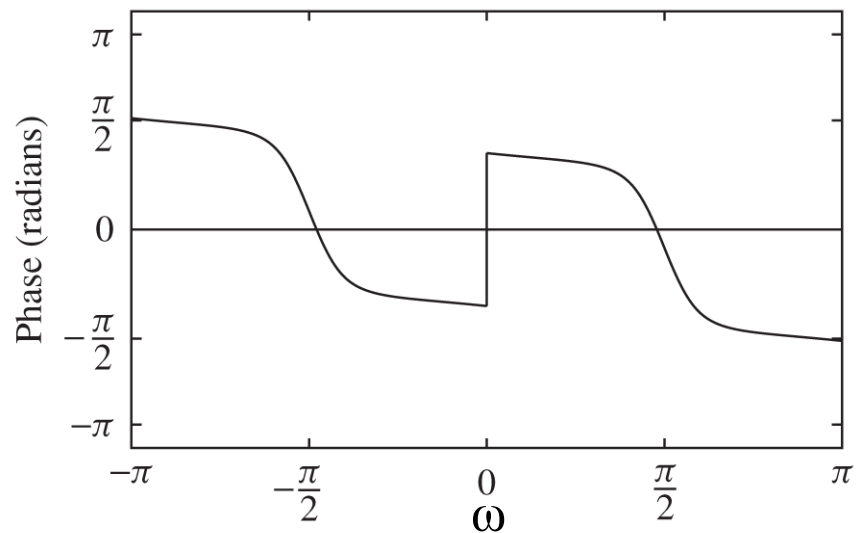
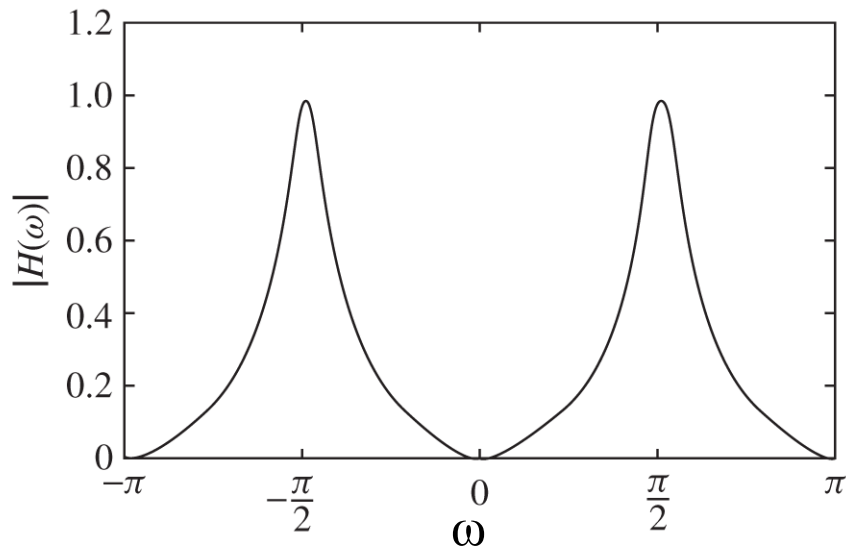

Simple LPF-to-HPF Transformation

If we have a lowpass filter but want to use it as a way to create a highpass filter that is easily done as follows.

We'll illustrate the idea using an ideal LPF (even though those don't really exist!):

$$|H_{lp}^f(\omega)|$$

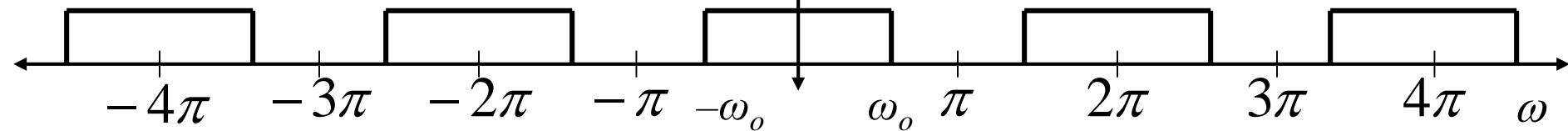

Shift this frequency response by π rad/sample:

$$|H_{lp}^f(\omega - \pi)| = |H_{hp}^f(\omega)|$$

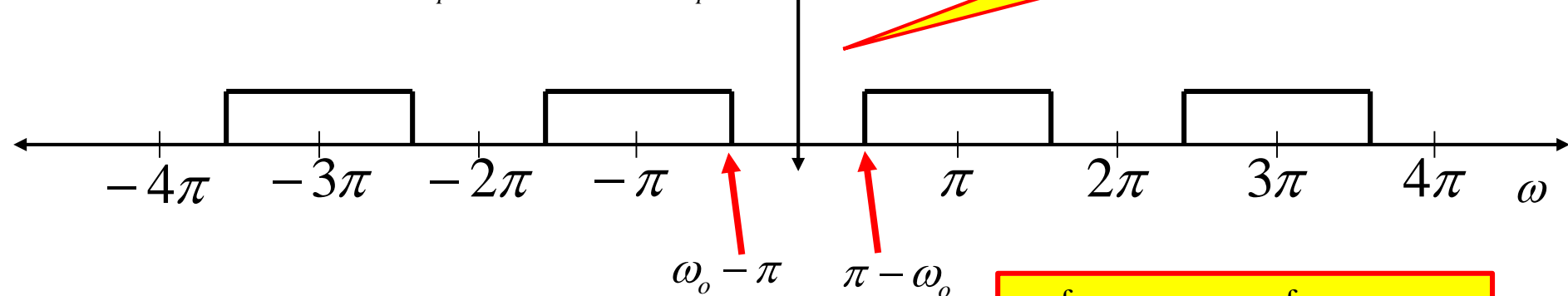

Gives HPF!!!

$$H_{hp}^f(\omega) = H_{lp}^f(\omega - \pi)$$

So... this gives us what we want... but how do we actually do it???

If the frequency response of the LPF is given by

$$H_{lp}^f(\omega) = \frac{\sum_{k=0}^M b_k e^{-j\omega k}}{1 + \sum_{k=1}^N a_k e^{-j\omega k}} \quad \rightarrow \quad H_{hp}^f(\omega) = H_{lp}^f(\omega - \pi) = \frac{\sum_{k=0}^M b_k e^{-j(\omega - \pi)k}}{1 + \sum_{k=1}^N a_k e^{-j(\omega - \pi)k}}$$

$e^{j\pi} = -1$

Coefficients of HPF

$$\rightarrow H_{hp}^f(\omega) = \frac{\sum_{k=0}^M b_k e^{j\pi k} e^{-j\omega k}}{1 + \sum_{k=1}^N a_k e^{j\pi k} e^{-j\omega k}} \quad \rightarrow \quad H_{hp}^f(\omega) = \frac{\sum_{k=0}^M b_k (-1)^k e^{-j\omega k}}{1 + \sum_{k=1}^N a_k (-1)^k e^{-j\omega k}}$$

Coefficients of HPF

Now changing focus to the transfer function:

$$H_{lp}^z(z) = \frac{\sum_{k=0}^M b_k z^{-k}}{1 + \sum_{k=1}^N a_k z^{-k}}$$

$$H_{hp}^z(z) = \frac{\sum_{k=0}^M b_k (-1)^k z^{-k}}{1 + \sum_{k=1}^N a_k (-1)^k z^{-k}} = \frac{\sum_{k=0}^M b_k (-z)^{-k}}{1 + \sum_{k=1}^N a_k (-z)^{-k}} = H_{lp}^z(-z)$$



$$H_{hp}^z(z) = H_{lp}^z(-z)$$

Flips poles & zeroes wrt the Im and Re axes

LPF PZ-Plot

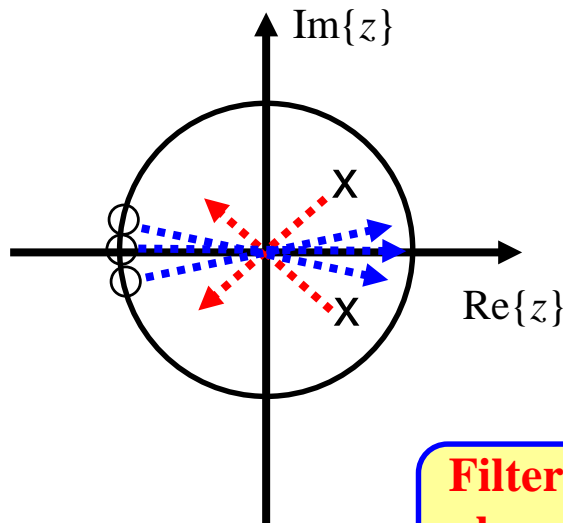

HPF PZ-Plot

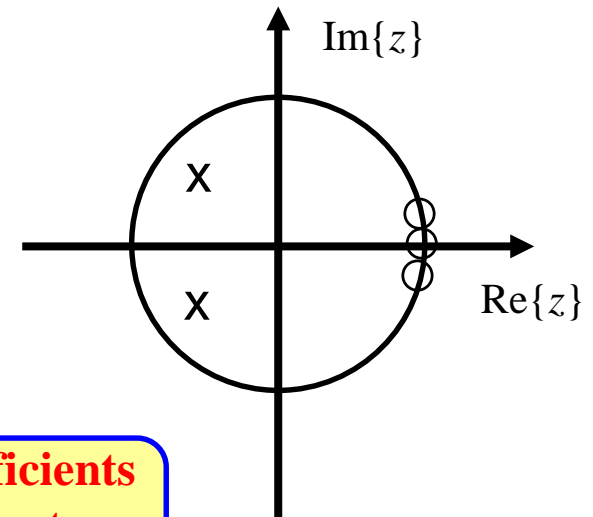

**Filters with real coefficients
have pole-zero symmetry
across the real axis**

And these results then impact the Difference Equation view:

$$y[n] = -\sum_{k=1}^N a_k y[n-k] + \sum_{k=0}^M b_k x[n-k]$$

Given D.E.
for LPF

Derived D.E.
for HPF

$$y[n] = -\sum_{k=1}^N (-1)^k a_k y[n-k] + \sum_{k=0}^M (-1)^k b_k x[n-k]$$

Suppose you don't have the TF, FR or DE.... But have the impulse response for a LPF...

Applying the modulation (frequency shift) property of DTFT gives

$$H_{hp}^f(\omega) = H_{lp}^f(\omega - \pi) \quad \Rightarrow \quad h_{hp}[n] = e^{j\pi n} h_{lp}[n]$$

$$\Rightarrow \quad h_{hp}[n] = (-1)^n h_{lp}[n]$$

Summary: LPF-to-HPF Transformation

$$H_{hp}^z(z) = H_{lp}^z(-z)$$

Flips poles/zeros

$$H_{hp}^f(\omega) = H_{lp}^f(\omega - \pi)$$

Shifts FR by π

$$h_{hp}[n] = (-1)^n h_{lp}[n]$$

Alternating sign change

$$H_{lp}^f(\omega) = \frac{\sum_{k=0}^M b_k e^{-j\omega k}}{1 + \sum_{k=1}^N a_k e^{-j\omega k}}$$



$$H_{hp}^f(\omega) = \frac{\sum_{k=0}^M b_k (-1)^k e^{-j\omega k}}{1 + \sum_{k=1}^N a_k (-1)^k e^{-j\omega k}}$$

$$H_{lp}^z(z) = \frac{\sum_{k=0}^M b_k z^{-k}}{1 + \sum_{k=1}^N a_k z^{-k}}$$



$$H_{hp}^z(z) = \frac{\sum_{k=0}^M b_k (-1)^k z^{-k}}{1 + \sum_{k=1}^N a_k (-1)^k z^{-k}}$$

$$y[n] = -\sum_{k=1}^N a_k y[n-k] + \sum_{k=0}^M b_k x[n-k]$$



$$y[n] = -\sum_{k=1}^N (-1)^k a_k y[n-k] + \sum_{k=0}^M (-1)^k b_k x[n-k]$$

Some Useful Filters Design by Pole-Zero Placement

Digital Resonators

Has two complex-conjugate poles placed near the UC to create a resonate peak at a desired frequency. Their location determines characteristics:

- Angle will be approximately at the resonant peak
- Radius determines how pronounced the peak is

Has two zeros that can be placed where desired... usually either

- Both at the origin
- One at $z = 1$ ($\omega = 0$) and one at $z = -1$ ($\omega = \pm\pi$)

Zeros at Origin

$$\begin{aligned} H^z(z) &= \frac{b_o}{(1 - re^{j\omega_o} z^{-1})(1 - re^{-j\omega_o} z^{-1})} \\ &= \frac{b_o}{1 - (2r \cos(\omega_o)) z^{-1} + r^2 z^{-2}} \end{aligned}$$

Zeros at $z = \pm 1$

$$\begin{aligned} H^z(z) &= G \frac{(1 - z^{-1})(1 + z^{-1})}{(1 - re^{j\omega_o} z^{-1})(1 - re^{-j\omega_o} z^{-1})} \\ &= G \frac{(1 - z^{-2})}{1 - (2r \cos(\omega_o)) z^{-1} + r^2 z^{-2}} \end{aligned}$$

Resonator w/ Zeros at the origin

$$H^z(z) = \frac{b_o}{(1 - re^{j\omega_o} z^{-1})(1 - re^{-j\omega_o} z^{-1})} = \frac{b_o}{1 - (2r \cos(\omega_o)) z^{-1} + r^2 z^{-2}}$$

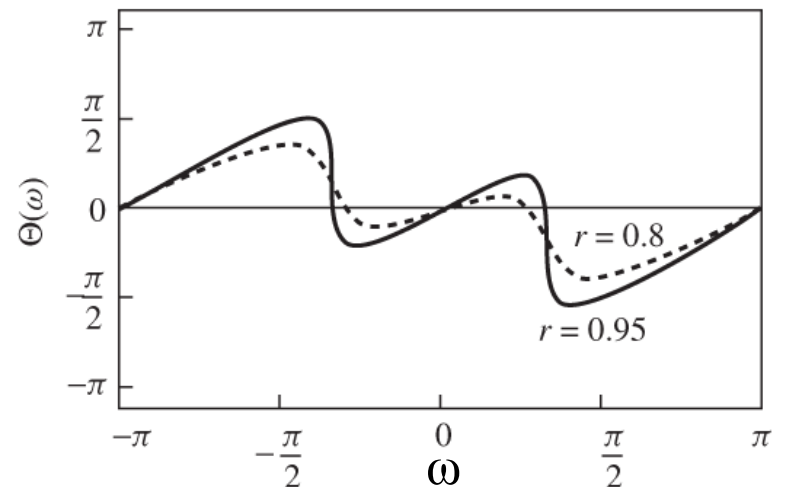
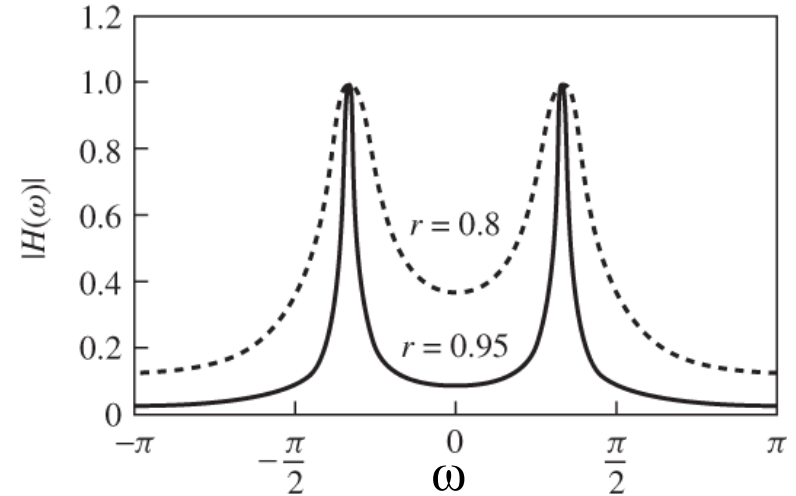
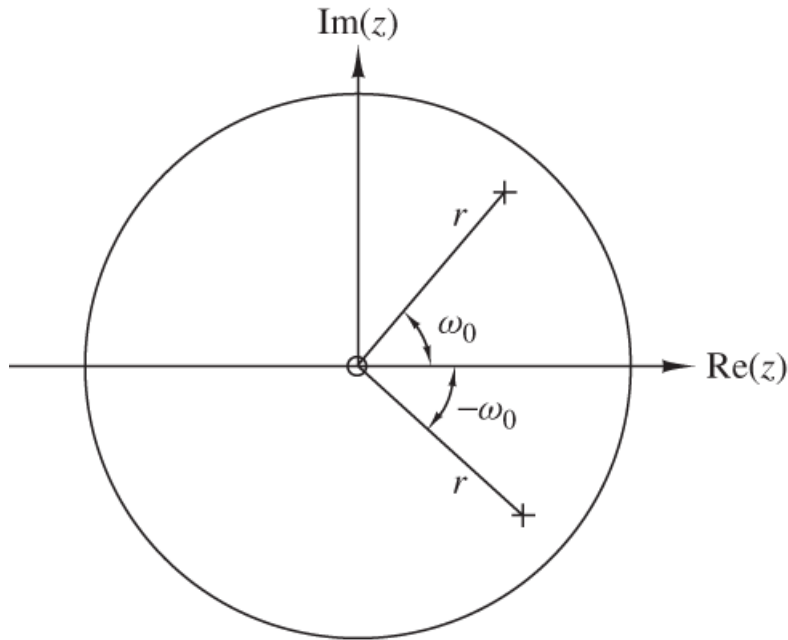

Book shows that:

$$\omega_r = \cos^{-1} \left(\frac{1+r^2}{2r} \cos(\omega_o) \right)$$

$$\Delta\omega_{3dB} \approx 2(1-r)$$

Resonator w/ Zeros at $z = \pm 1$

$$H^z(z) = G \frac{(1 - z^{-1})(1 + z^{-1})}{(1 - re^{j\omega_0} z^{-1})(1 - re^{-j\omega_0} z^{-1})} = G \frac{(1 - z^{-2})}{1 - (2r \cos(\omega_0)) z^{-1} + r^2 z^{-2}}$$

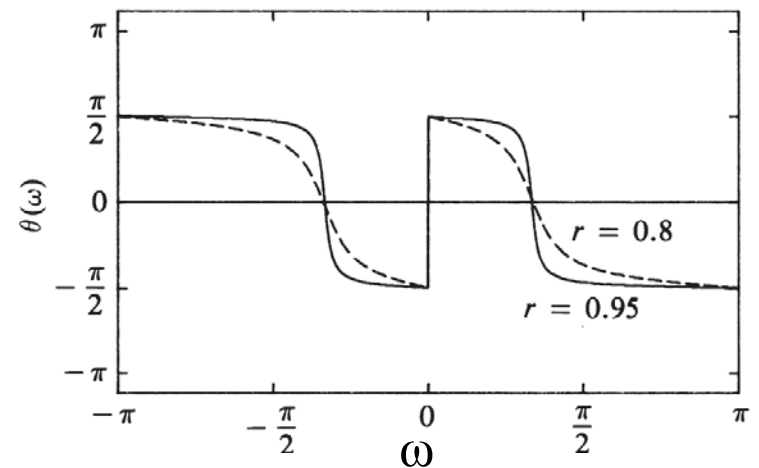
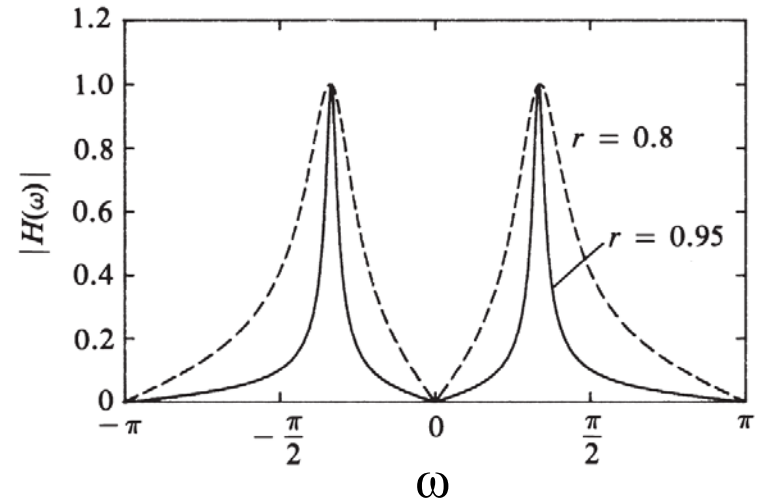
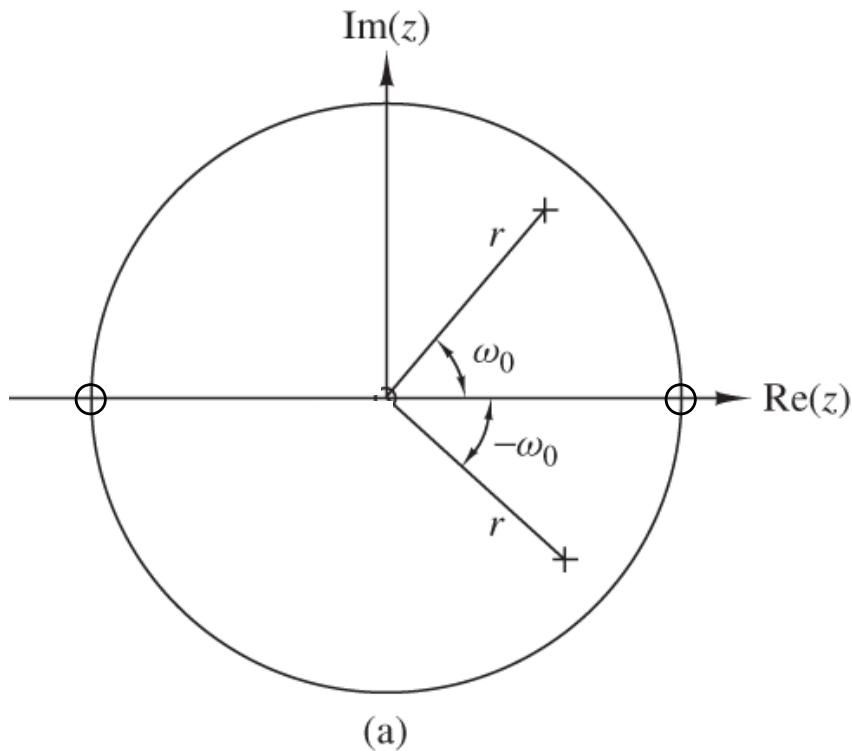

Oscillator

$$H^z(z) = \frac{b_o}{(1 - re^{j\omega_o} z^{-1})(1 - re^{-j\omega_o} z^{-1})}$$
$$= \frac{b_o}{1 - (2r \cos(\omega_o)) z^{-1} + r^2 z^{-2}}$$

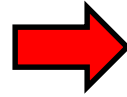

$$h[n] = \frac{b_o r^n}{\sin(\omega_o)} \sin(\omega_o (n + 1)) u[n]$$

If we put the pole on the unit circle ($r = 1$) then this impulse response does not decay and the system can be used as an oscillator.

For more details see Sect. 5.4.7 of the text book.

Notch Filters

This simple version has two complex-conjugate zeros placed on the UC to create a null at a desired frequency. Their angle will be at the null frequency

Has two poles that can be placed where desired... usually either

- Both at the origin (this results in an FIR filter)
- Two complex-conjugate poles at $p_{1,2} = re^{\pm j\omega_0}$

Poles at Origin

$$\begin{aligned}H^z(z) &= b_o (1 - e^{j\omega_0} z^{-1})(1 - e^{-j\omega_0} z^{-1}) \\ &= b_o (1 - 2\cos(\omega_0)z^{-1} + z^{-2}) \\ &= \frac{b_o (z^2 - 2\cos(\omega_0)z + 1)}{z^2}\end{aligned}$$

Poles at $p_{1,2} = re^{\pm j\omega_0}$

$$\begin{aligned}H^z(z) &= \frac{b_o (1 - e^{j\omega_0} z^{-1})(1 - e^{-j\omega_0} z^{-1})}{(1 - re^{j\omega_0} z^{-1})(1 - re^{-j\omega_0} z^{-1})} \\ &= \frac{b_o (1 - 2\cos(\omega_0)z^{-1} + z^{-2})}{(1 - 2r\cos(\omega_0)z^{-1} + r^2 z^{-2})} \\ &= \frac{b_o (z^2 - 2\cos(\omega_0)z + 1)}{(z^2 - 2r\cos(\omega_0)z + r^2)}\end{aligned}$$

Poles at Origin

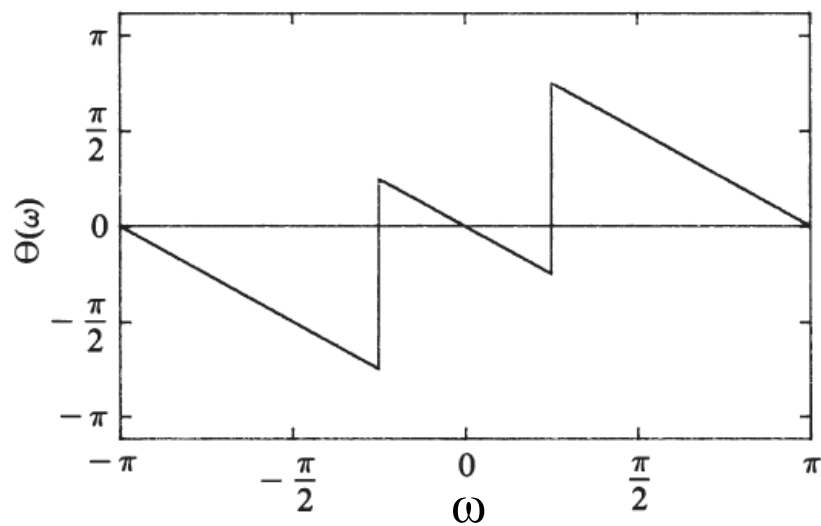
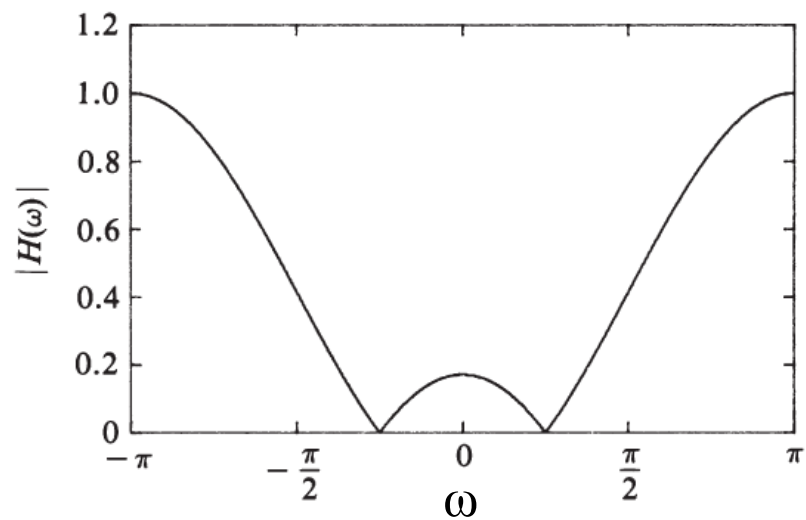

Poles at $p_{1,2} = re^{\pm j\omega_0}$

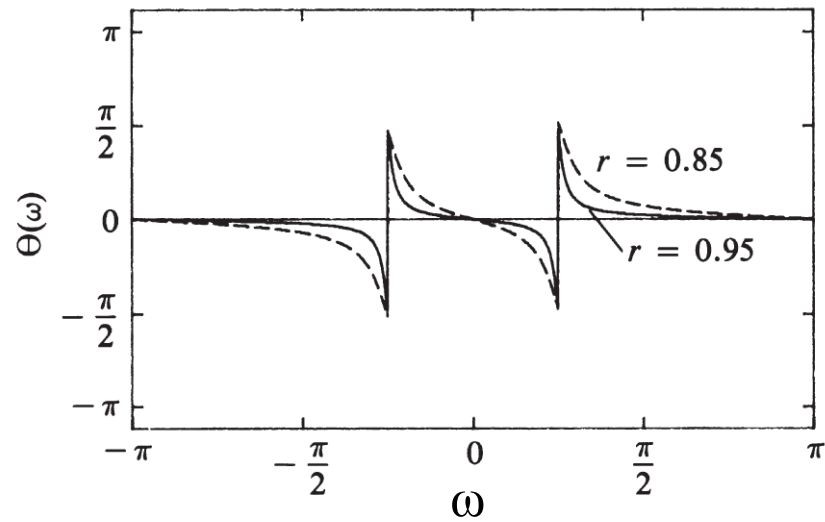
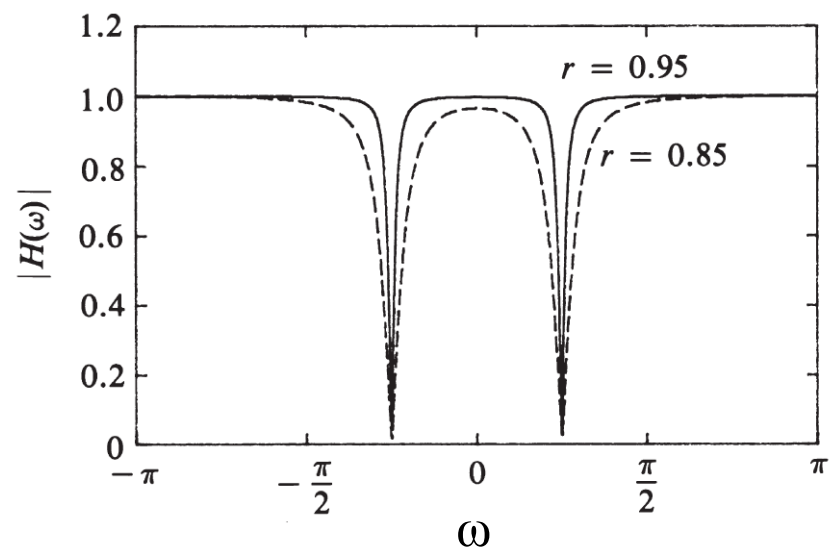

Comb Filters These have a variety of uses.... When you have harmonics that either need to be passed and/or stopped.

The name comes from the fact that these filters have a FR magnitude that looks like a comb – many “teeth”.

M Even

Simplest form is an FIR filter with “uniform weights”: $y[n] = \frac{1}{M+1} \sum_{k=0}^M x[n-k]$

Transfer Function: $H^z(z) = \frac{1}{M+1} \sum_{k=0}^M z^{-k}$

zeros @ $z = e^{j2\pi k/(M+1)}$,
 $k = 0, 1, \dots, M$

$$= \frac{1}{M+1} \left[\frac{1 - z^{-(M+1)}}{1 - z^{-1}} \right]$$

Pole @ $z = 1$ (cancelled
by zero @ $z = 1$)

Impulse Response: $h[n] = \frac{1}{M+1} \left[\underset{\uparrow}{1} \quad 1 \quad \dots \quad 1 \right]$

Rectangle
starting @ $n = 0$

Frequency Response: $H^f(\omega) = \frac{e^{-j\omega M/2}}{M+1} \left[\frac{\sin(\omega(M+1)/2)}{\sin(\omega/2)} \right]$

Found by taking DTFT of rectangle starting at 0 (use time-shift property)

Taking a look at the frequency response over the $[-\pi, \pi]$ range:

$$H^f(\omega) = \frac{e^{-j\omega M/2}}{M+1} \left[\frac{\sin(\omega(M+1)/2)}{\sin(\omega/2)} \right]$$

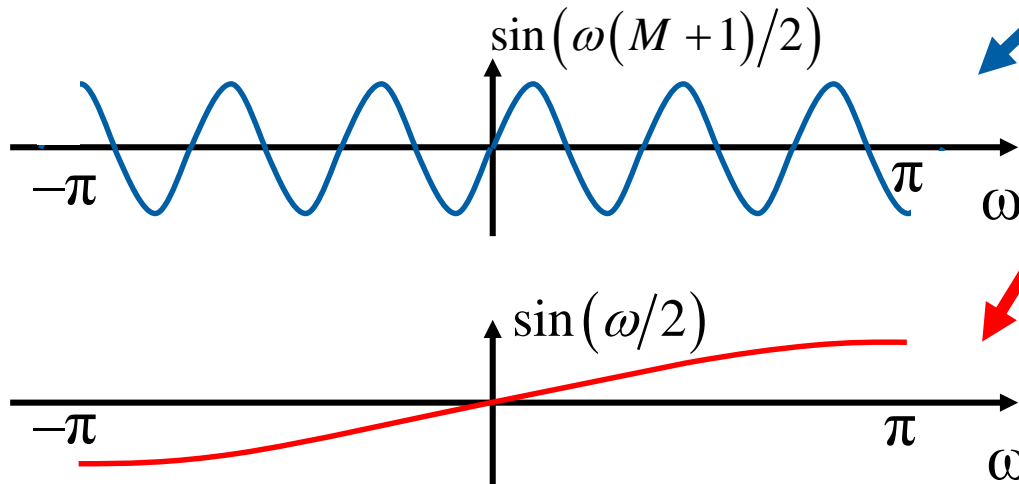

Numerator is zero when
 $\omega(M+1)/2 = k\pi$
 \downarrow
 $\omega = k2\pi/(M+1)$

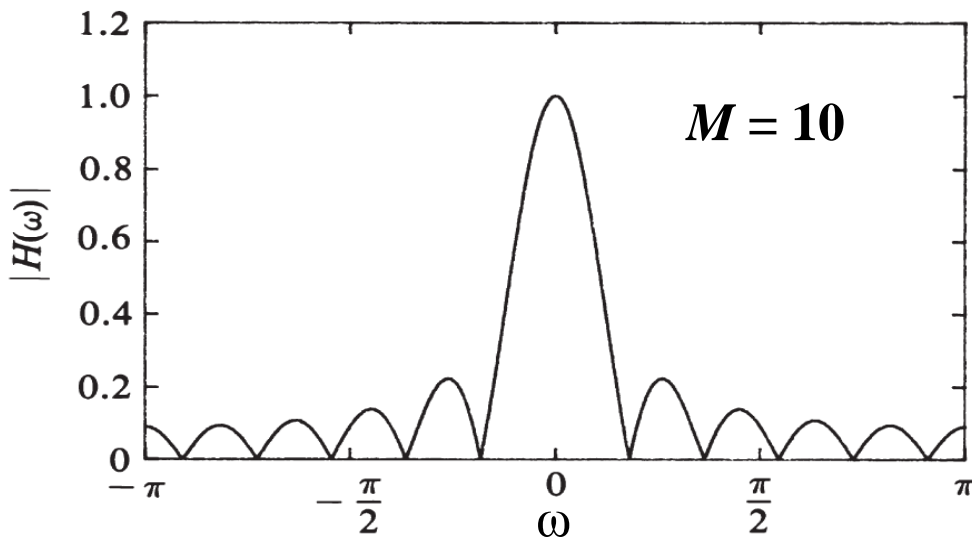

More General Approach

Start with some FIR filter $H^z(z) = \sum_{k=0}^M h[k]z^{-k}$

Replace z by z^L where L is a positive integer: $H_L^z(z) = \sum_{k=0}^M h[k]z^{-kL}$

The resulting frequency response is $H_L^f(\omega) = \sum_{k=0}^M h[k]e^{-jkL\omega} = H^f(L\omega)$

“Scrunches” by factor of L ... e.g., when $\omega = \pi/L$ we get the original FR's point at π

Illustrate with triangle FR... not a real FIR's shape! Just easy to see!

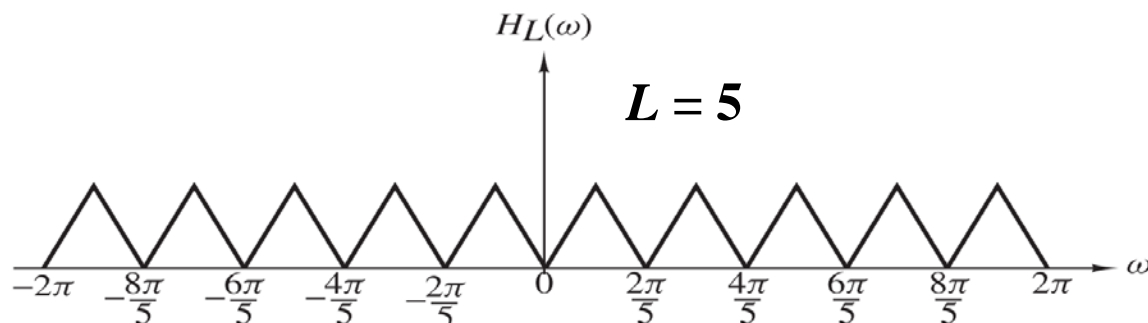
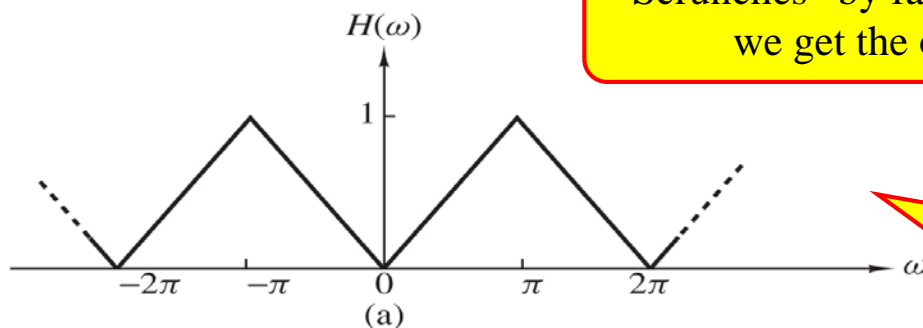

Let's see what $z \rightarrow z^L$ does from an impulse response and block diagram viewpoint.

$$H_L^z(z) = \sum_{k=0}^M h[k]z^{-kL} = h[0] + h[1]z^{-L} + h[2]z^{-2L} + \dots + h[M]z^{-ML}$$

$$= h[0] + \underbrace{0z^{-1} + \dots + 0z^{-(L-1)}}_{\substack{\text{L 0s inserted between} \\ h[0] \ \& \ h[1]}} + h[1]z^{-L} + \underbrace{0z^{-(L+1)} + \dots + 0z^{-(2L-1)}}_{\substack{\text{L 0s inserted between} \\ h[1] \ \& \ h[2]}} + h[2]z^{-2L} + \dots + h[M]z^{-ML} \quad \text{etc.}$$

$$h_L[n] = [h[0] \quad \underbrace{0 \dots 0}_{\text{L 0s}} \quad h[1] \quad \underbrace{0 \dots 0}_{\text{L 0s}} \quad h[2] \quad \underbrace{0 \dots 0}_{\text{L 0s}} \quad h[3] \quad \dots \quad \underbrace{0 \dots 0}_{\text{L 0s}} \quad h[M]]$$

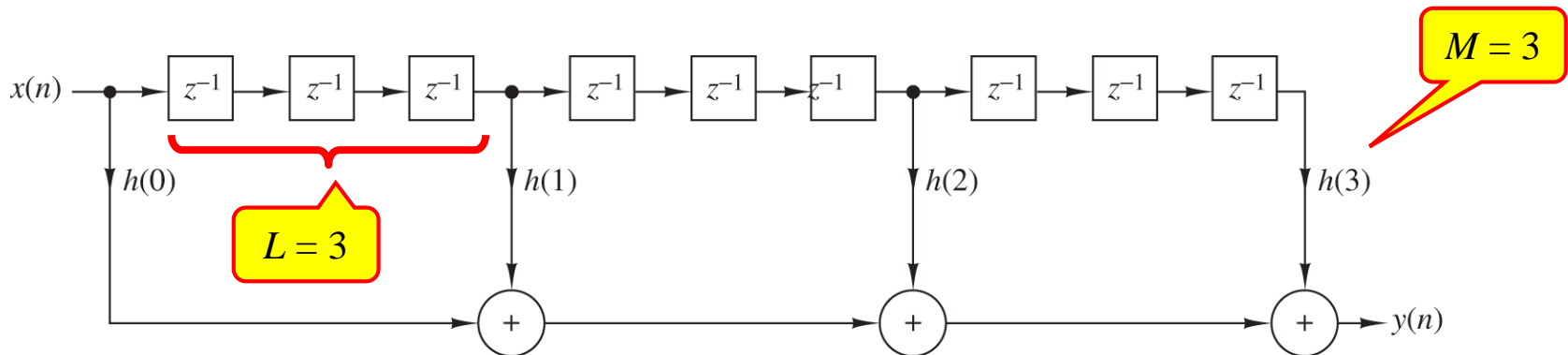

Applying this idea to the uniform weight FIR filter we get

Transfer Function:
$$H^z(z) = \frac{1}{M+1} \left[\frac{1 - z^{-L(M+1)}}{1 - z^{-L}} \right]$$

Frequency Response:
$$H^f(\omega) = \frac{e^{-j\omega LM/2}}{M+1} \left[\frac{\sin(\omega L(M+1)/2)}{\sin(\omega L/2)} \right]$$

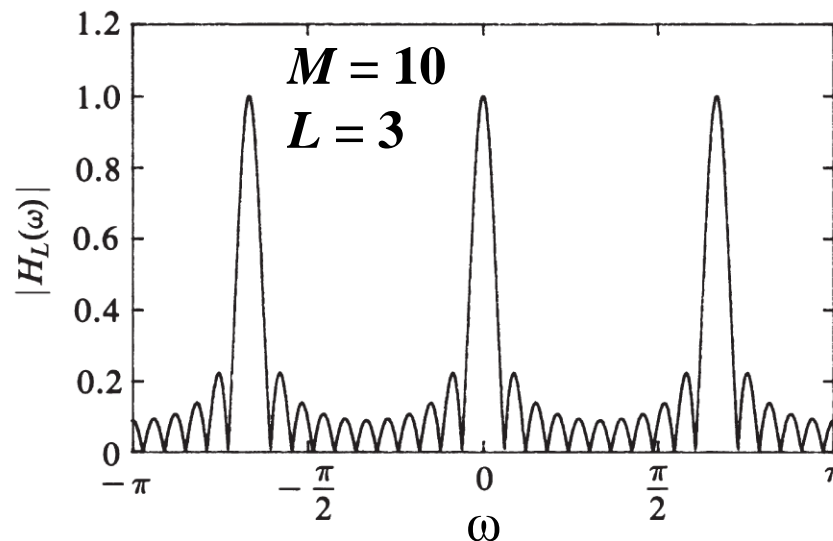

See book's discussion of the use of such a comb filter to separate solar harmonics from lunar harmonics in ionospheric measurements!

All-Pass Filters These have constant magnitude response everywhere! So what is their purpose??!! They are used to modify the phase response of an existing system without changing its magnitude response (i.e., “Phase Equalization”)

For some given real-valued coefficients $\{a_k\}$

Define the polynomial $A(z) = \sum_{k=0}^N a_k z^{-k}$, $a_0 = 1$

Then an all-pass filter can be formed as $H_{ap}^z(z) = z^{-N} \frac{A(z^{-1})}{A(z)}$

We can easily verify that this is indeed all-pass:

$$|H_{ap}^f(\omega)|^2 = \left[H_{ap}^z(z) H_{ap}^z(z^{-1}) \right]_{z=e^{j\omega}} = \left[\left[z^{-N} \frac{A(z^{-1})}{A(z)} \right] \left[z^N \frac{A(z)}{A(z^{-1})} \right] \right]_{z=e^{j\omega}} = 1$$

So as long as the filter is former like this, the filter is all-pass regardless of the values of the coefficients $\{a_k\}$... so the coefficients can be chosen to try to achieve a desired phase response!

All-Pass Pole-Zero Reciprocal Locations

Because $A(z)$ is in the denominator and $A(z^{-1})$ is in numerator, if there is a pole at z_p then there is a zero at $1/z_p$. In other words, poles and zeros occur in reciprocal pairs

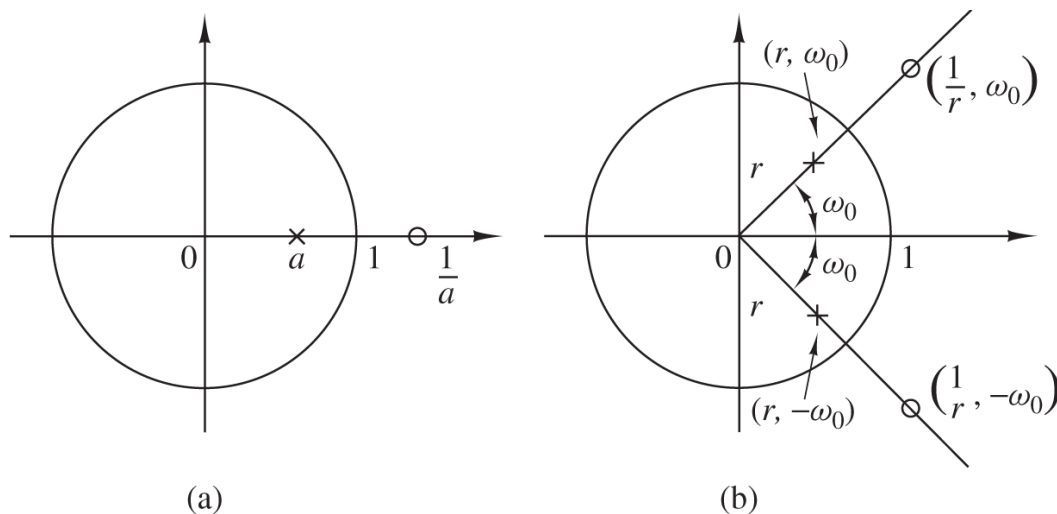

Figure 5.4.16 Pole-zero patterns of (a) a first-order and (b) a second-order all-pass filter.

General form for All-Pass Filter

$$H_{ap}^z(z) = \left[\prod_{k=1}^{N_R} \frac{z^{-1} - \alpha_k}{1 - \alpha_k z^{-1}} \right] \left[\prod_{k=1}^{N_C} \frac{(z^{-1} - \beta_k)(z^{-1} - \beta_k^*)}{(1 - \beta_k z^{-1})(1 - \beta_k^* z^{-1})} \right]$$

$N_R =$ Real pole/zero
Reciprocal Pairs

$N_C =$ Real pole/zero
Conjugate/Reciprocal Quads